F , 5 (6 Inspection Hatch

6 L] H P P [P P
Fire Rated up to 60 Minutes
No Framing, Stopping or Sealants Required.

Description

The F , 5 (6 7 2 3 Inspection Hatch is a lightweight (2.6kg) alternative to other fire rated hatches. The hatch is designed to eliminate fire and smoke penetration and to provide an easy installing process eliminating expensive and disruptive construction - in other words, fast and simple installation. New technology lightweight components are combined in a unique system to maintain the fire integrity of any barrier. No additional finishing to surrounds or the hatch is required as the steel cover plate is powder coated to create a pleasing and unobtrusive finish.

Features

The F , 5 (6 7 2 3 Hatch is designed to give inspection access, while eliminating expensive and disruptive construction. The inspection hatch can be successfully used for new installations, interior refits and retrospective requirements in both commercial and domestic constructions. The Hatch has been fire tested to AS1530.4 2014 by BRANZ () in plasterboard / ceilings without additional support framing. Once installed no additional finishing to surrounds is required.

Physical Properties

The hatches are fabricated from 16 gauge cold rolled zintex steel frame (fire rated) with an 18 gauge zintex steel cover (fire rated). An

aluminium covered “nano technology” board is combined with the zintex steel to create the required thermal and fire barrier. The use of “nano technology” provides the complete protection and level of performance required, while at the same time providing a lightweight easily installed hatch assembly. Intumescent protection integrated in the design eliminates the passage of cold and hot gases. The use of “nano technology” provides the complete protection and level of performance required, while at the same time providing a lightweight easily installed good looking hatch assembly. The exposed face of the hatch cover has a powdercoated finish eliminating any after installation treatment.

Installation Techniques

Cut a hole in the fire barrier using the frame as a template. The FIRESTOP Inspection Hatch does not require any framing in plasterboard, although existing framing can be used where available. Place a load spreader at each corner and fix with the supplied screws.

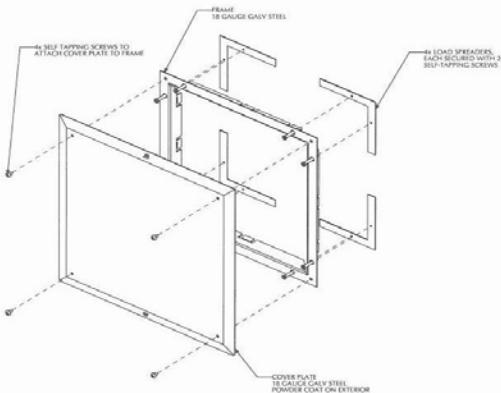

For both ceiling and wall hatches, before fixing the cover plate, bend the four tabs closest to the corners inwards to 90°. This provides support for the insulating fire panel when the cover is attached. Position the cover plate over the frame and screw the four cover plate screws to the frame. Finally, cover the screw heads with the plastic covers provided and remove the protective plastic sheet.

Application

The FIRESTOP Inspection Hatch is ideal when access is required through a wall or ceiling for inspection or maintenance.

Maintenance

No maintenance should be required when installed in accordance with the technical installation instructions. Once installed, if any section of the hatch is damaged, the damaged section should be removed and replaced. Replacement cover plate screws may be collected from Firestop Centre at no charge.

The information contained in this document is based on available tests of components used in the manufacturer of these hatches. This product data sheet does not purport to be a test or to utilise any test results other than those specified in the technical report. The manufacturer warrants the FIRESTOP Inspection Hatch will be free from defects in materials for 90 days from the date of purchase.